

# THINK

# WEAVING

# DYNAMIC

India's Leading Manufacturer of Advanced Textile Weaving Machines

The Company

## Dynamic Autolooms India Pvt Ltd

A pioneering innovation-driven engineering and technology manufacturing company trusted by **more than 3000 companies** having installed more than **1,50,000 weaving machines.**



Dynamic Autolooms India Pvt. Ltd. is a pioneer in the weaving industry since 1976. Serving the domestic as well as international markets through advanced rapier looms and shuttle looms.

Dynamic's products are an integration of the experience earned over decades with the proficiency of the modern era's technologies. We cater to fabric manufacturers ranging from the apparel industry to technical and industrial textile manufacturers. **We believe that the cost is long forgotten and only the quality is remembered forever.**

Dynamic Looms has been trusted since decades for changing the way fabrics are manufactured in different textile sectors. We have created a benchmark in the industry by providing latest Rapier and Shuttle Looms equipped with modernized technologies and streamlined production process.

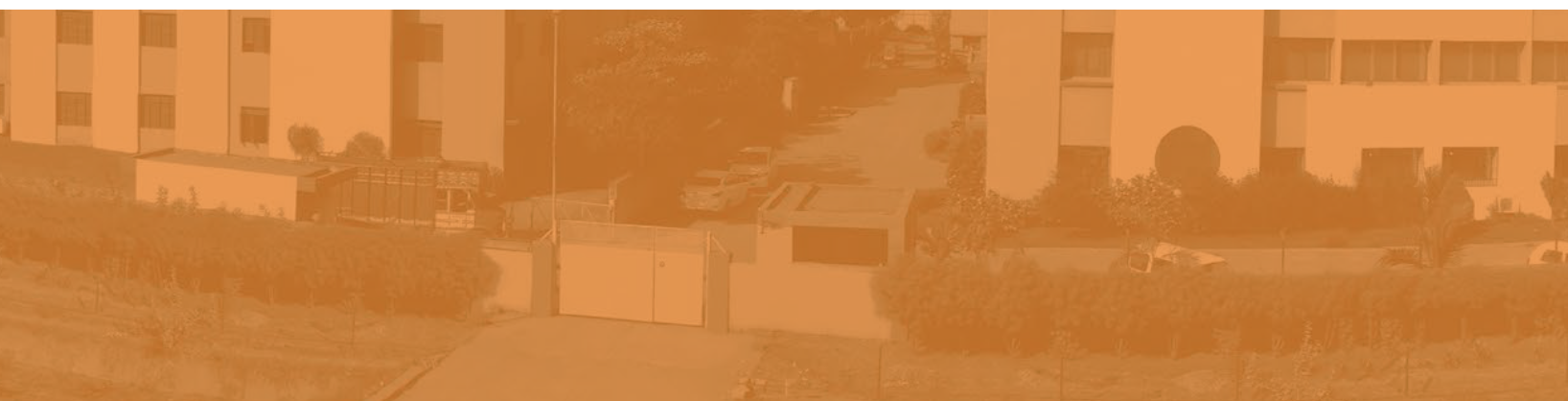

## A MESSAGE FROM MD

Mr. Mittal Patel



## OUR VISION

### "ENGINEERING YOUR CREATIVITY INTO REALITY"

Dynamic is primarily an innovation-driven engineering and technology company. Our fundamental aim is to create such machines that are the choice of weavers of the present as well as of the future.

The philosophy behind our innovations is that **no kind of textile creativity should be hampered by the lack of technological availability.**

We are always researching and developing new products and upgrading existing ones so that the textile creativity of future generations can get free expression.

Rather than simply an autoloom manufacturing company, we wish to be identified as **an innovative engineering and manufacturing company whose aims are set on meeting the needs of the present and future.**

We firmly believe that **businesses and industries must employ engineering and technological advances for the betterment of the environment and the world.**

New companies in the Dynamic group of companies such as Dynamic Equipments Pvt. Ltd. are solely focused on providing engineering and technological products for the betterment of the environment.

# CORE VALUES

## CUSTOMER FIRST

We believe that customer is the backbone of any business. Our primary priority in any form of dealings is meeting the requirement of the customer and ensuring complete solution.

## CLARITY

We ensure complete clarity in our dealings with customers and vendors. We believe that clarity in communications is fundamental for successful business.

## COMMITMENT

Once a customer of Dynamic should always remain a customer of Dynamic. We are committed to provide best quality products and after sales services. We value the investment of our customers and are committed to deliver on that investment.

## INNOVATION

Our R & D never stops. We always strive to bring new technical innovations by new products and improving existing products. An ever growing perfection is what we always strive towards.

# SHIVA DR II PLUS

## RAPIER WEAVING MACHINE

INSTALLED  
MORE THAN  
**10,000**  
MACHINES

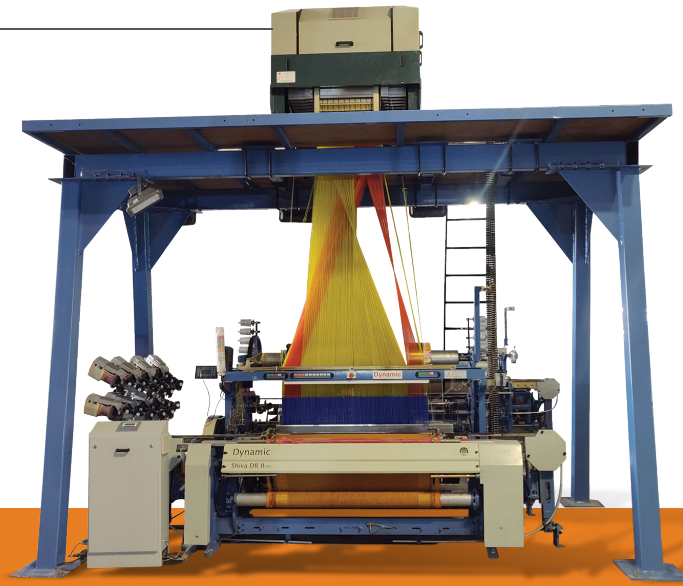

### TECHNICAL SPECIFICATIONS

Model	SHIVA DR II PLUS
Machine Type	Heavy Duty Flexible Rapier Loom
Loom Width	170, 190, 230, 280, 330 CM
Working Width	50 MM less than loom width
Weft Insertion Rate	400 to 525 MPM
Weft Colors	2, 4, 6, 8 operated by Microcontroller (Optional) / Synchronized with Electronic Dobby or Electronic Jacquard
Warp Control	Electrical 6 Rows / Infrared (Optional)
Weft Control	Piezo Electronic Sensor
Shedding Motion	Cam Motion (Plain, Twill, Sateen, Matt Weave) / Electronic Dobby / Electronic Jacquard
Let-off	Positive Mechanical / Separate Beam type / Double Beam Attachment (Optional) / with an independent motor, Electronically controlled by Microcontroller
Take up	7 Wheel / with an independent motor, Electronically controlled by Microcontroller
Weft Density	10 to 128 Picks per Inch / Up to 250 Picks per Inch (Optional) / Variable Density up to 5 (Optional) / Cramming (Optional) / Fringing (Optional)
Cloth Roll	Up to 400 MM Dia
Lubrication	Centralized
Installed Power	1.5 KW / 3.3 KW
Special Attachment (Optional)	Suction Device

### Applicable Yarns

Blended / Cotton: 2 Ne - 100 Ne  
Filament: 20 D – 2000 D  
Pure Silk: 20 D – 500 D

### SPACE REQUIRED FOR INSTALLATION:

Reed Space	170 CM	190 CM	230 CM	280 CM	330 CM
Length (ft)	12'9"	13'5"	14'10"	17'11"	19'7"
Width (ft)	6' 7"	6' 7"	6' 7"	6' 7"	6' 7"

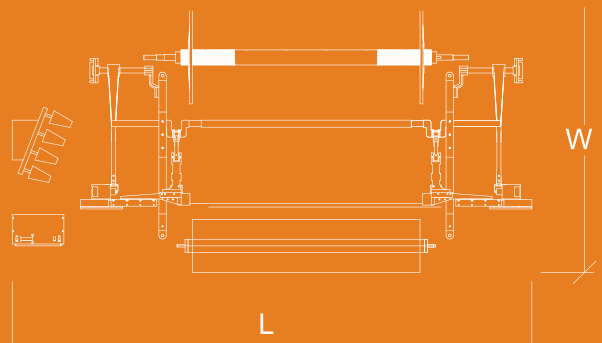

India's first ever indigenously developed machine

## INDIGENOUSLY DEVELOPED MACHINE

### CONTROLLED & EFFECTIVE ELECTRONIC LET-OFF MECHANISM

---

- Mounting mechanism of Whip Roller and Load-cell are specifically designed to get proper response of Warp Sheet Tension.
- Continuous unwinding of Beam.
- Keep identified Warp Sheet / Beam Tension and record it for the future reference.
- Almost Constant Tension on Warp Sheet right from full to empty Beam.
- Weaving of Even Fabric from first meter to last meter.
- Lower & Upper Warp Sheet Tension's safety feature reduces multiple warp breakages.
- Few number of Parts thus less Maintenance.

### USER FRIENDLY & STURDY AUTOMATION

---

- Indigenously Developed Automation.
- Noticeably reduction in no. of parts in the machine due to Automation.
- Quick change of Parameters certainly saving time.



### VERSATILE ELECTRONIC TAKE UP MOTION GENERATES NUMBER OF POSSIBILITIES

---

- Wants to change PPI? it is a matter of just pressing a finger.
- Continuous movement resulting into Uniformity in woven Fabric.
- 5 Variable Densities unfolds wide scope of Value Addition Weaving Design.
- Fringing option adds one more feather in the Woven Fabric.
- Cramming of Wefts makes remarkable difference in the Fabric Design.
- Extremely Less Parts thus less Maintenance.

### EASY CORRECTIONS OF LET-OFF & TAKE UP WITH MORE OPTIONS

---

To Tackle the Starting Mark Damage, below mentioned options are readily available:

- Forward Kick of Let-off
- Forward Kick of Take Up
- Let-off "ON" Delay
- Take Up "ON" Delay
- Reverse Kick of Let-off
- Reverse Kick of Take Up
- Let-off "OFF" Delay
- Take Up "OFF" Delay

# DEJ - 21

## ELECTRONIC JACQUARD



### TECHNICAL SPECIFICATIONS

No. of Hooks	Speed	Application
640, 960, 1408, 1536, 2688	Up to 250	Shuttle Loom Low Speed Rapier Loom

# DEJ - 22

## HIGH SPEED ELECTRONIC JACQUARD

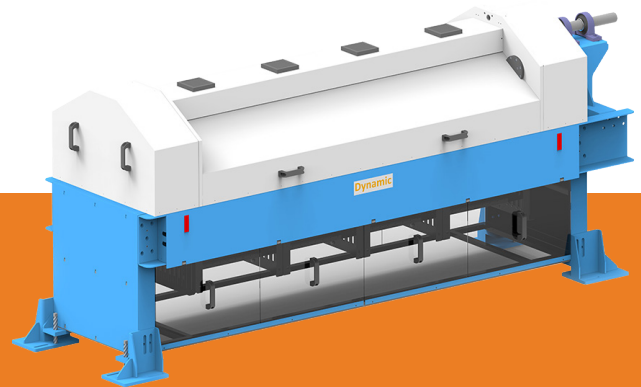

### TECHNICAL SPECIFICATIONS

No. of Hooks	Speed	Application
2688, 5376 (Jumbo Jacquard)	Up to 500	Low Speed Rapier Loom High Speed Rapier Loom

# GANESHA

## SEMI AUTOMATIC DROP BOX LOOM

LEGACY  
PRODUCT

INSTALLED  
MORE THAN  
**1,50,000**  
MACHINES



First time in India, Introducing with unique **Dynashed™** Positive Shedding Mechanism

### TECHNICAL SPECIFICATIONS

Model	GANESHA
Machine Type	Semi Automatic Drop Box Shuttle Looms
Picking	Under pick motion Loom
Width	45", 52", 56", 60", 64", 68", 72", 80"
Working Width	2" less than loom width
Reed:	Fast
Shuttle Box	4x4, 2x2, 4x1, 2x1, 1x1
Shedding Motion	Tappet, Dobby, Jacquard
Weft Control	Weft fork system or electronic infra-red filler system (optional)
Warp Control	Electrical or Mechanical warp Stop (optional)
Let-Off	Semi Positive attached/separate beam type
Take-Up	Seven wheel take-up mechanism
Cloth roll	VTM system / Spring Loaded (Optional)
Applicable Yarns	Synthetic, Silk, Polyester
Lubrication	Centralized lubrication system (Optional)

### MACHINE CONTROL (OPTIONAL)

- Microprocessor based control panel
- Electro-magnetic brake motor
- Push Button System: i.e. Start/Stop/One Pick/Inching/Reverse
- Pick counting
- Predetermined stop
- RPM indicator
- Beam over tension stop

### SPACE REQUIRED FOR INSTALLATION:

Reed Space	45"	52"	56"	60"	64"	68"	72"	80"
Length (ft)	8' 8"	9' 4"	9' 8"	10'	10' 4"	10' 8"	11'	11' 8"
Width (ft)	6'	6'	6'	6'	6'	6'	6'	6'

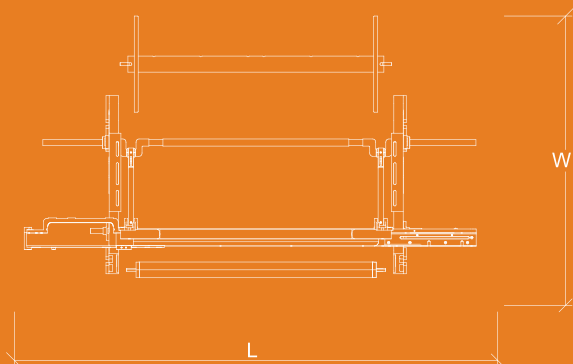

### **Manufactured by**

#### **Dynamic Autolooms India Pvt. Ltd.**

Plot No. 2, Road No. 1, Phase - I, GIDC, Kathwada

Ahmedabad - 382 430, Gujarat, India

PH: +91-79-22901522, +91-79-29707124

+91-9925039411, +91-9825413411

CELL: +91-98798 44411

Email: sales@dynamiclooms.com

www.dynamiclooms.com

### **Sales Office**

#### **Dynamic Autolooms India Pvt. Ltd.**

Shop No. A/10 to A/11, Tulsi Market

Behind Rushabh Petrol Pump

Opp Fire Bridge Station

Ring Road, Surat, Gujarat, India

PH: +91-261-2302379

CELL: +91-97277 52960

